

*This is just a quick reference sheet, please always refer to the full written rules as per the Pair Acro Catalogue + Note: Total DD in the reference sheets includes the BM value of 0.10*



**Throw (“W”) or a Jump (“J”):** a disconnect should be clearly seen. The f-swimmer must be completely in the AIR (top of the head and toes must be above the surface at the same time).



**Somersault Allowance:** 90° less than declared = BM

**Twist Allowances:**

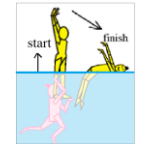
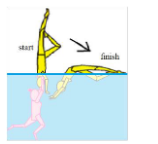
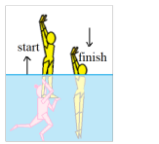
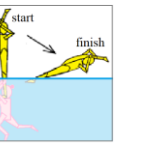
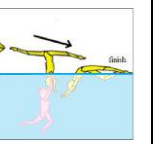
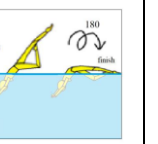
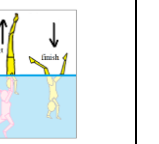

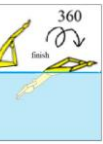
- **Head-Down Lifts/Throws:** Calculate no. of rotations until above the knee(s) (kneecaps must be visible) of f-swimmer.
- **Lifts/Jumps that are head-up:** Calculate no. of rotations until the waist level of the f-swimmer.
- **360° declared twists and more:** 90° less than declared = BM
- **180° declared twists:** There is no allowance – performing less than 180° is BM. It must be done precisely (or more).

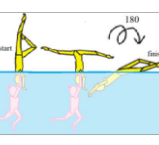
**LIFTS:**

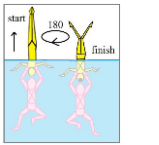
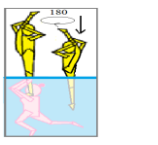
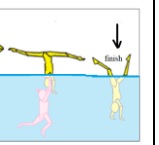
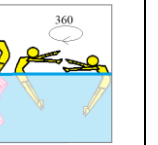
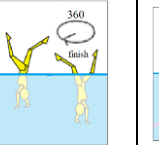
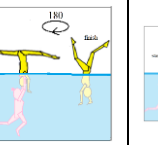
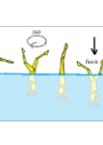
Cat. No.	1	2	3	4	5	6	7	8	9
<b>Name</b>	Lift head-up with crashing	Lift legs-up with crashing	Lift head-up	Lift head-up with flexibility and crashing	Lift legs-up with flexibility and crashing	Lift legs-up with crashing + rotation 180°	Lift legs-up	Lift head-up with flexibility	Lift legs-up with crashing + rotation 360°
<b>Diagram</b>									
<b>Code</b>	<b>L»</b>	<b>L!»</b>	<b>L</b>	<b>Lf»</b>	<b>Llf»</b>	<b>L!r0.5»</b>	<b>L!</b>	<b>Lf</b>	<b>L!r1»</b>
<b>Total DD</b>	<b>0.20</b>	<b>0.30</b>	<b>0.50</b>	<b>0.50</b>	<b>0.50</b>	<b>0.50</b>	<b>0.70</b>	<b>0.70</b>	<b>0.70</b>

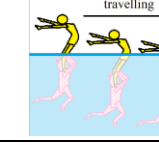
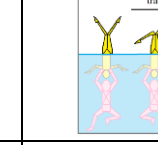
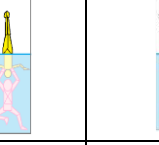
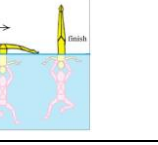

Cat. No.	10	11	13	14	15	17	20	21	27
<b>Name</b>	Lift legs-up with crashing, flex, + rotation 180° (turn)	Lift head-up + 180° rotation	Lift legs-up + 180° rotation	Lift head up + flexibility and rotation 180°	Lift legs-up with flexibility	Lift head up + rotation 360°	Lift legs-up + rotation 360°	Lift legs-up with flexibility and rotation 180°	Lift legs-up with flexibility and rotation 360°
<b>Diagram</b>									
<b>Code</b>	<b>L!fr0.5»</b>	<b>Lr0.5</b>	<b>L!r0.5</b>	<b>Lfr0.5</b>	<b>L!f</b>	<b>Lr1</b>	<b>L!r1</b>	<b>L!fr0.5</b>	<b>L!fr1</b>
<b>Total DD</b>	<b>0.70</b>	<b>0.70</b>	<b>0.90</b>	<b>0.90</b>	<b>0.90</b>	<b>0.90</b>	<b>1.10</b>	<b>1.10</b>	<b>1.30</b>

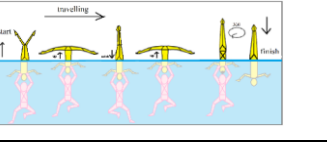
**SUSTAINED LIFTS:**

Cat. No.	12	16	22	23	28	47
<b>Name</b>	Sust. Lift head-up with travel	Sust. Lift legs-up with travel	Sust. Lift legs-up with flex and travel	Sust. Lift legs-up + travel and rotation 180° or more	Sust. Lift legs-up + flex, travel and rot. 180° or more	Sust. Lift + travel + 2 consec. flex pushes with catch + rot. 360°
<b>Diagram</b>						
<b>Code</b>	<b>SL&gt;</b>	<b>SL!»</b>	<b>SL!f&gt;</b>	<b>S!r0.5&gt;</b>	<b>S!fr0.5&gt;</b>	<b>SL!f2+r1&gt;</b>
<b>Total DD</b>	<b>0.90</b>	<b>0.90</b>	<b>1.10</b>	<b>1.10</b>	<b>1.30</b>	<b>2.20</b>

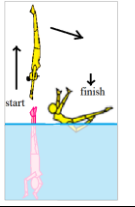
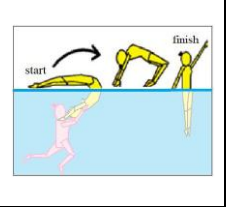
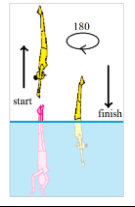
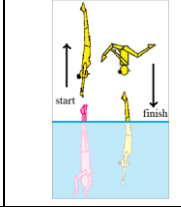
**THROWS:**

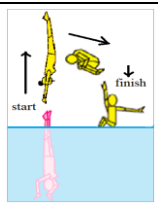
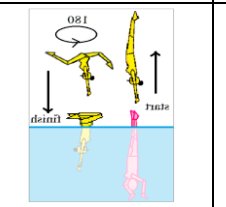

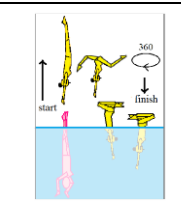
Cat. No.	19	26	29	30
<b>Name</b>	Throw legs up with crashing	Legs-Up Throw-Dive	Throw legs up + 180° rotation	Throw legs up with flexibility
<b>Diagram</b>				
<b>Code</b>	<b>W!»</b>	<b>W!d</b>	<b>W!r0.5</b>	<b>W!f</b>
<b>Total DD</b>	<b>0.90</b>	<b>1.10</b>	<b>1.30</b>	<b>1.30</b>

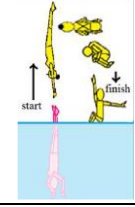
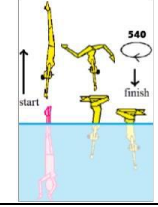
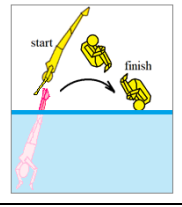
Cat. No.	33	34	36	38
<b>Name</b>	Throw legs up + 180° somer.	Thow legs up + flex & rotn 180°	Throw legs up + rotation 360°	Throw-legs up + flex & rotn 360° or more
<b>Diagram</b>				
<b>Code</b>	<b>W!s0.5</b>	<b>W!fr0.5</b>	<b>W!r1</b>	<b>W!fr1</b>
<b>Total DD</b>	<b>1.50</b>	<b>1.50</b>	<b>1.50</b>	<b>1.70</b>

Cat. No.	40	42	49
<b>Name</b>	Throw legs-up + 180 somer. and half twist	Throw legs up + flex & rotation 540°	Throw legs up with 1 somersault forwards
<b>Diagram</b>			
<b>Code</b>	<b>W!s0.5t0.5</b>	<b>W!fr1.5</b>	<b>W!s1F</b>
<b>Total DD</b>	<b>1.70</b>	<b>1.90</b>	<b>2.30</b>

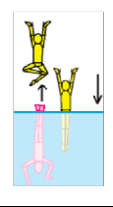
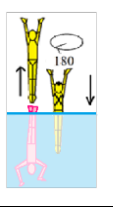
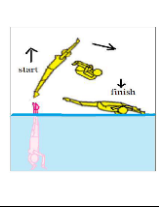
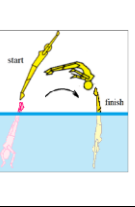
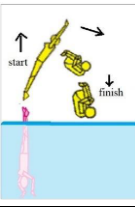
**JUMPS:**

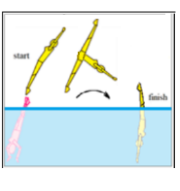
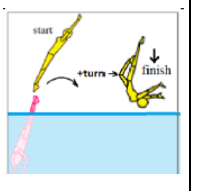
18	24	25	31	32	35
<b>Name</b>	Jump head-up	Jump head-up + 180° rotn	Jump head-up + flexibility	Jump head-up + 180° back somer.	Jump-Tuck/Change position - Dive
<b>Diagram</b>					
<b>J</b>	<b>Jr0.5</b>	<b>Jf</b>	<b>Jd</b>	<b>Js0.5B</b>	<b>Jpd</b>
<b>0.90</b>	<b>1.10</b>	<b>1.10</b>	<b>1.30</b>	<b>1.30</b>	<b>1.50</b>

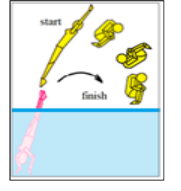
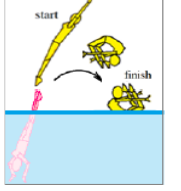
37	39	41	43	44	
<b>Name</b>	Jump head-up with flex+ dive	Jump head-up + 1/2 twist and 180 somer.	Jump head-up + 1 somersault backwards	Jump-Tuck-1 somer + 1/2 twist	Jump head-up with 1 somer. back + flex
<b>Diagram</b>					
<b>Jdf</b>	<b>Js0.5t0.5</b>	<b>Js1B</b>	<b>JBs1t0.5</b>	<b>Jfs1B</b>	
<b>1.60</b>	<b>1.70</b>	<b>1.90</b>	<b>2.10</b>	<b>2.10</b>	

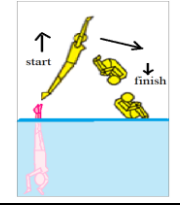
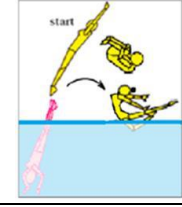
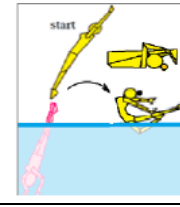
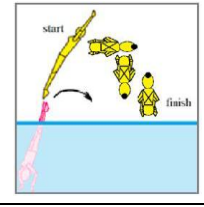
45	46	48	50	
<b>Name</b>	Jump head-up with 1 somersault forwards	Jump head-up with 1 somersault backwards + open in Jay (flexibility)	Jump head-up with 1 somersault backwards + Pike + open in Jay (flex)	Jump head-up-Backwards - Frontal 360 somersault
<b>Diagram</b>				
<b>Js1F</b>	<b>Js1B+f</b>	<b>Js1B+pf</b>	<b>JsF1B</b>	
<b>2.10</b>	<b>2.20</b>	<b>2.25</b>	<b>2.30</b>	